



*“The Heavy Duty P&F system
for loads up to 6.000 kg”*

POWER & FREE CONVEYOR

TYPE P&F420

The flexible P&F system with a load capacity up to 6.000 kg.

Simple and reliable accumulation of wagons in in line, 45° and in 90° buffer zones.

Minimum accumulation distance - 400 mm.

Smooth trolley transfer from one conveyor circuit to another minimizes the use of transfer units, thus lowering systems costs.

Unique trolley- and accumulation stop design ensures an instant and a highly reliable separation of wagons in the accumulating zones.

The use of modular components offers total flexibility and liberty in configuring the conveyor circuit layout.

Consequent use of tested quality components giving confidence in operation even in very harsh working environments.

Noiseless accumulation by means of non friction disengagement of the trolleys from the conveyor chain drive.

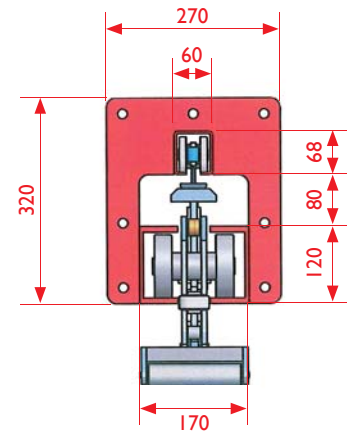
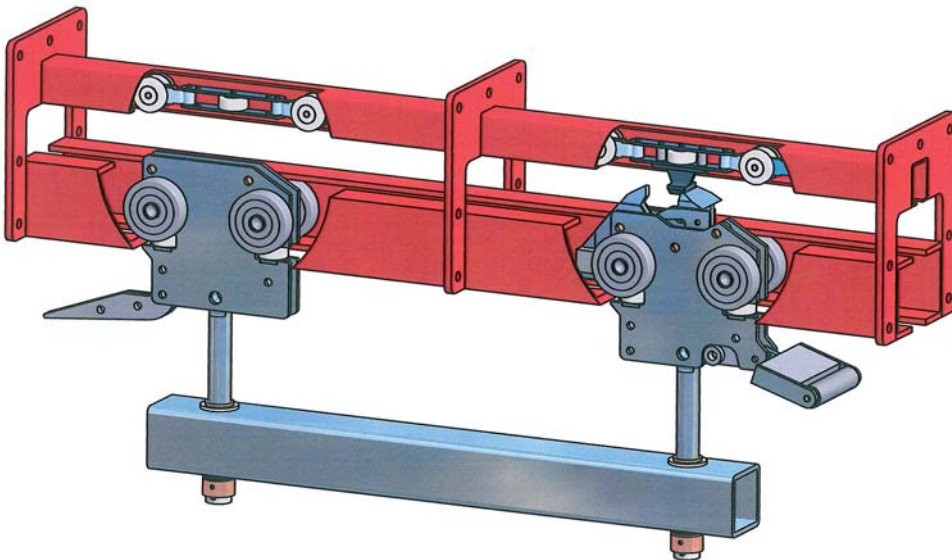

Specifications:

The Power & Free conveyor type P&F 420 consists of two Caldan straight profiles. In the upper "Power" profile a cardan chain is driven by one or more drive units.

In the underlying "Free" profile the wagons are driven by power chain carriers, via pivotal pawls attached to the front and back of the trolley.

Both the chain carrier pitch and the accumulation distance is designed according to customer request.

The wagons can, according to handling requirement, be separated and accumulated either in line, or at 45° or 90° within accumulation zones.

When routed into a closed accumulation stop, or when reaching the "tail" of the previous trolley, the trolley's accumulation lever is lifted and the pawl units are lowered. Hereby the trolley is disengaged from the chain carriers.

Conveyance with loads in up to 45° rise and fall sections - depending on the load - is possible due to a uniquely constructed link between the chain carriers and the trolley pawls.

Technical data:

Chain carrier pitch: 180 / 270 mm
 Max. chain pull: 400 kg
 Max. temperature (surrounding): 250° C
 Max. load per trolley (4-wheeled): 1000 kg
 Max. load per wagon (load bar with 2 / 4 or 8 trolleys): 2.000 / 4.000 / 6.000 kg
 Standard length, straight profile: 3.000 mm
 Trolley wheels / chain bearings: Open or sealed and greased version

Horizontal curves:
 Degree: 90° / 45° / 30° / 15°
 Radius: Min 1.500 mm

Vertical curves: Depending on work-load

Drive unit: Straight version with double sided caterpillar drive or 90° version with driving wheel. Gear motor with fixed or variable speed

Tension unit: Manual or pneumatic/ weight-loaded
 Switching gate: Manual, pneumatic or electrical version
 Vertical drop- and lift section: Available in guided/ floor mounted version or unguided and suspended from the ceiling

Accumulating stop: Pneumatic or electrical version

Pneumatic lubrication: Semi- or fully automatic version. Point- or fog lubrication of the cardan chain and / or the trolleys

Special designs: E.g. turning stations
 Accumulation possibilities: Automatic. In-line, 90° and 45°